



**Vacuum
Truck
Supplies**

QUALITY - INTEGRITY - COMMITMENT

EVAC 800

PORTABLE VACUUM UNIT

DESIGNED & CONSTRUCTED FOR BOTH VACUUM AND PRESSURE OPERATION

- *Stainless steel construction*
- *800L waste capacity*
- *300L water capacity*

SUITABLE FOR:

All forms of liquid / sludge wastes

- *Sewerage*
- *Septic*
- *Portable toilet*
- *Feedlot / agriculture sludges*
- *Aquaculture / fish waste*
- *Industrial*
- *Concrete cutting waste*
- *Paint booth sludges*
- *Communication pits*
- *Oily waters*
- *Waste cooking oil*
- *Many other wastes too!*

AUSTRALIA'S ONLY

AS1210 CL3 AND AS4343 EPA COMPLIANT PORTABLE VACUUM UNIT

Can be registered with Worksafe as plant equipment





**Vacuum
Truck
Supplies**

QUALITY - INTEGRITY - COMMITMENT

EVAC 800

PORTABLE VACUUM UNIT

FEATURES AND BENEFITS

The VTS EVAC range is suited to all forms of liquid and sludge type wastes (not designed for hydro excavation or DG wastes). Proven rugged design coupled with stainless steel construction to wet areas means the full EVAC range will last a long long time. Top quality components from Europe and the US coupled with VTS's "simple is more" design makes for a cost effective and practical solution.

Australian Standard compliance is essential in today's business environments. The VTS EVAC range meets AS1210 for Pressure Vessels and also AS4343 for Hazard Levels. Don't leave yourself open to hefty fines due to non compliance!

VACUUM TANK

- Constructed from 5mm GR304 Stainless Steel
- Mounted on a mild steel skid frame, able to be forklifted from all four sides
- Top wash out manway
- Sight Glasses to observe waste level in tank
- Tie Down and lifting points
- 680kg empty weight
- Dimensions 1527mm L, 1280mm W, 1750mm H

VACUUM SYSTEM

- 70 CFM Conde vacuum pump, vacuum and pressure capable
- Honda 5.5hp petrol engine (Optional Hatz 6hp diesel) with battery and electric start
- 50mm vacuum system, 10m of suction hose fitted with 75mm inlet to tank and blockage access
- 75mm discharge valve
- Primary Shut Off
- Secondary Shut Off
- Oil Catch Muffler
- Pressure relief valve and Vacuum relief valve
- Vacuum and Pressure Gauge

WATER SYSTEM

- 300 litre fresh water capacity with sight tube
- Honda petrol powered water pump 25mm
- Retractable steel hose reel with 15m of water delivery hose

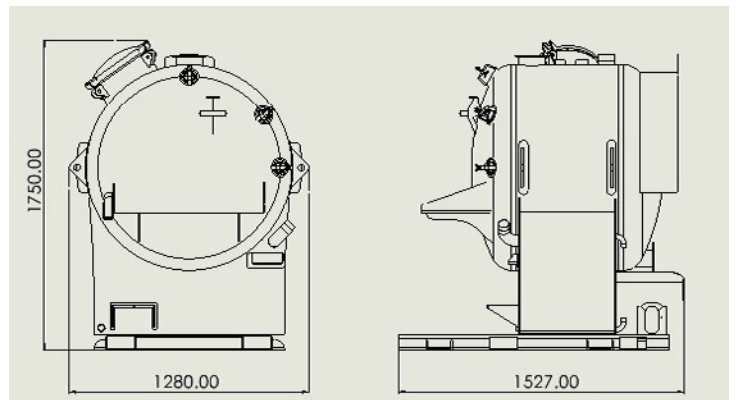

ABN 65 100 691 503

8 STEPHEN RD (PO BOX 4133),
DANDENONG STH VIC 3164
PH: 03 9792 4251 MOB: 0431 638 224